

FISA TEHNICA

PRODUSUL: Hidrant portativ DN100IB, iesire 1 x B, cu un racord fix tip B (3" sau 75 mm), fara robinet

FURNIZOR: S.C.
Mihai Bravu, nr.

Gefil S.A. – Ploiesti, str.
276A, Jud. Prahova

**CARACTERISTICI TEHNICE:**

Diametru- DN100

Material- Aluminiu

Presiunea de lucru- 16 bar

Presiunea de testare- 24 bar

Inaltime- 1000 mm

Latime- 335 mm

Adancimea filetelui: 145 mm

CARACTERISTICI DE UTILIZARE:

Hidrantii portativi se folosesc pentru cuplarea hidrantilor subterani de furtunurile de refulare din dotarea unitatilor de pompieri, racordarea la hidrantul subteran pentru alimentarea cu apa a utilajelor de stins incendii precum si la alte necesitati. Acestia pot avea diametrul de 80 respectiv 100 mm, pot avea una sau 2 iesiri tip B (75 mm) sau C (52 mm).

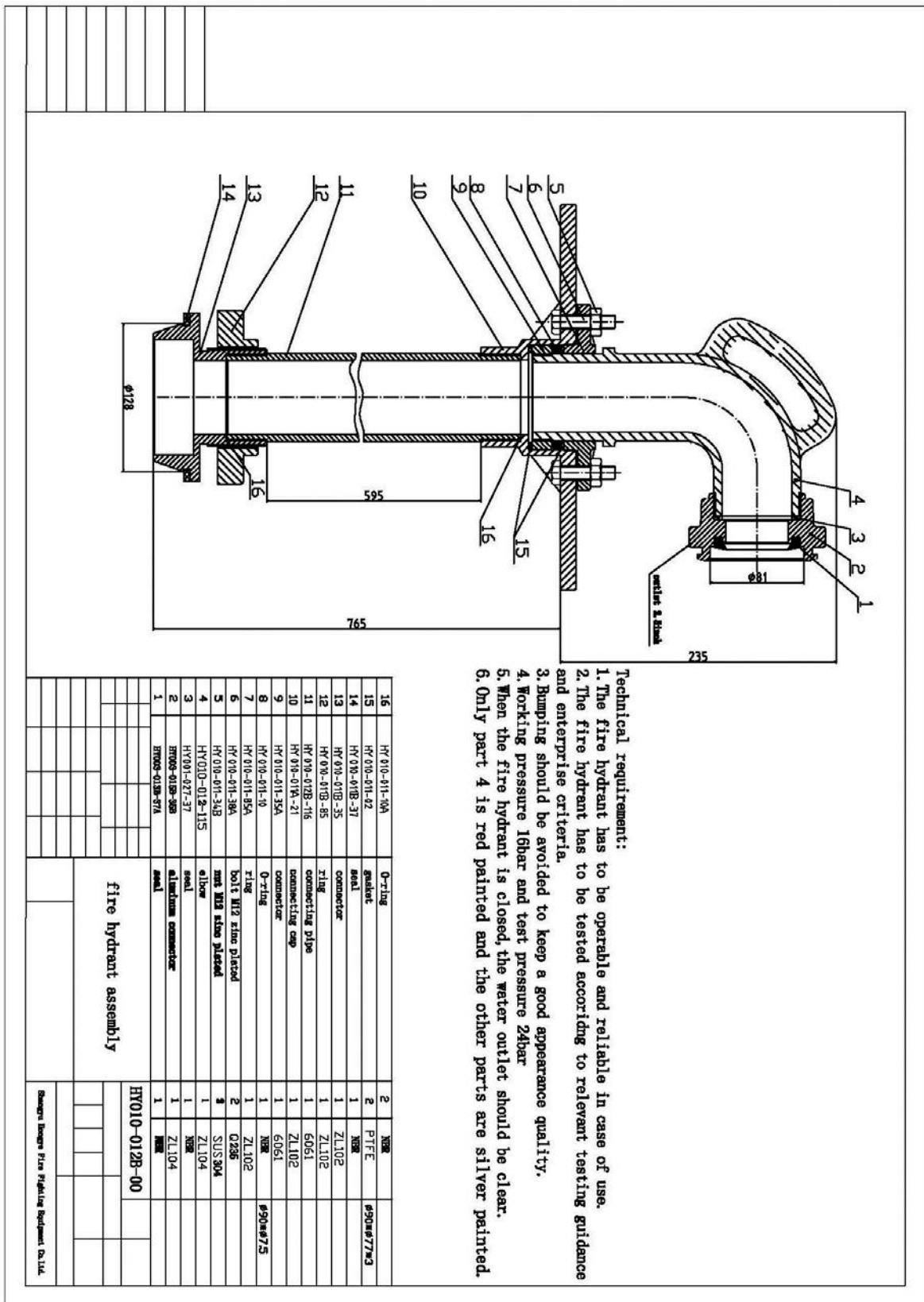

- Technical requirement:**
1. The fire hydrant has to be operable and reliable in case of use.
 2. The fire hydrant has to be tested according to relevant testing guidance and enterprise criteria.
 3. Bumping should be avoided to keep a good appearance quality.
 4. Working pressure 16bar and test pressure 24bar
 5. When the fire hydrant is closed, the water outlet should be clear.
 6. Only part 4 is red painted and the other parts are silver painted.

16	HY 010-011-004	O-ring	2	NBR	
15	HY 010-011-02	gasket	2	PTFE	#90#77#3
14	HY 010-018-31	seal	1	NBR	
13	HY 010-018-35	connector	1	ZL102	
12	HY 010-018-85	ring	1	ZL102	
11	HY 010-018-116	connecting pipe	1	6061	
10	HY 010-018-21	connecting cap	1	ZL102	
9	HY 010-011-35A	connector	1	6061	
8	HY 010-011-0	O-ring	1	NBR	#90##75
7	HY 010-011-85A	ring	1	ZL102	
6	HY 010-011-86A	bolt M12 zinc plated	2	Q235	
5	HY 010-011-34B	nut M12 zinc plated	3	SUS304	
4	HY010-012-115	elbow	1	ZL104	
3	HY001-021-37	seal	1	NBR	
2	HY001-018-88	aluminum connector	1	ZL104	
1	HY001-018-87A	seal	1	NBR	

fire hydrant assembly

HY010-012B-00

Shangri Shengri Fire Fighting Equipment Co., Ltd.